

1:2

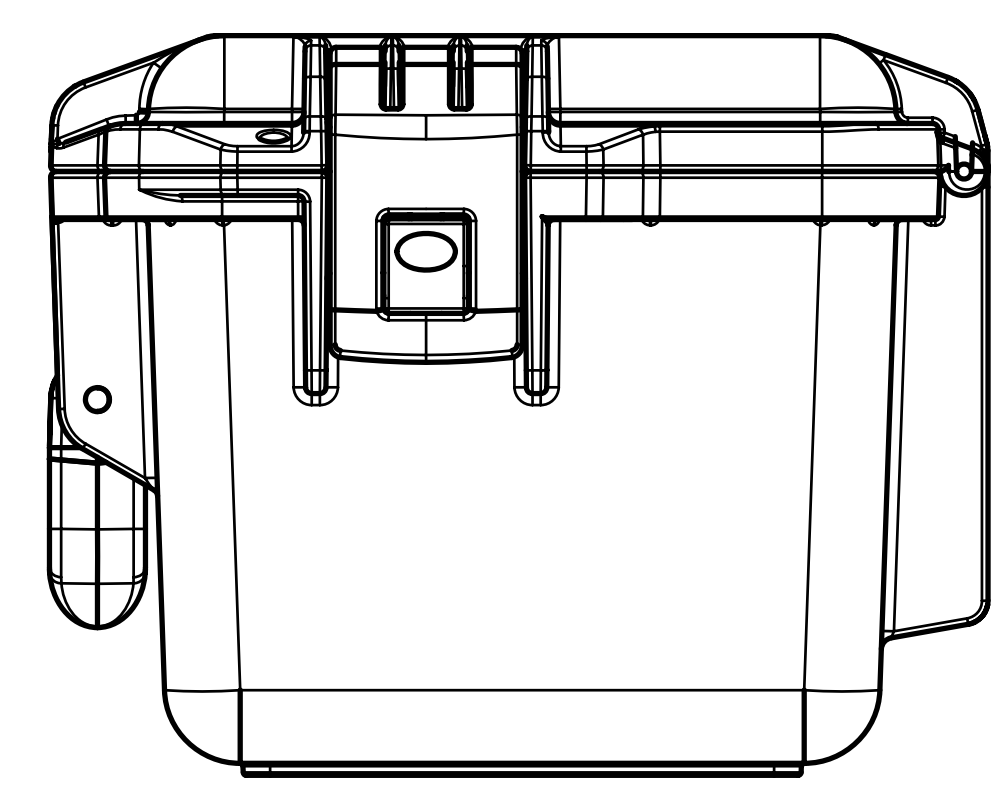
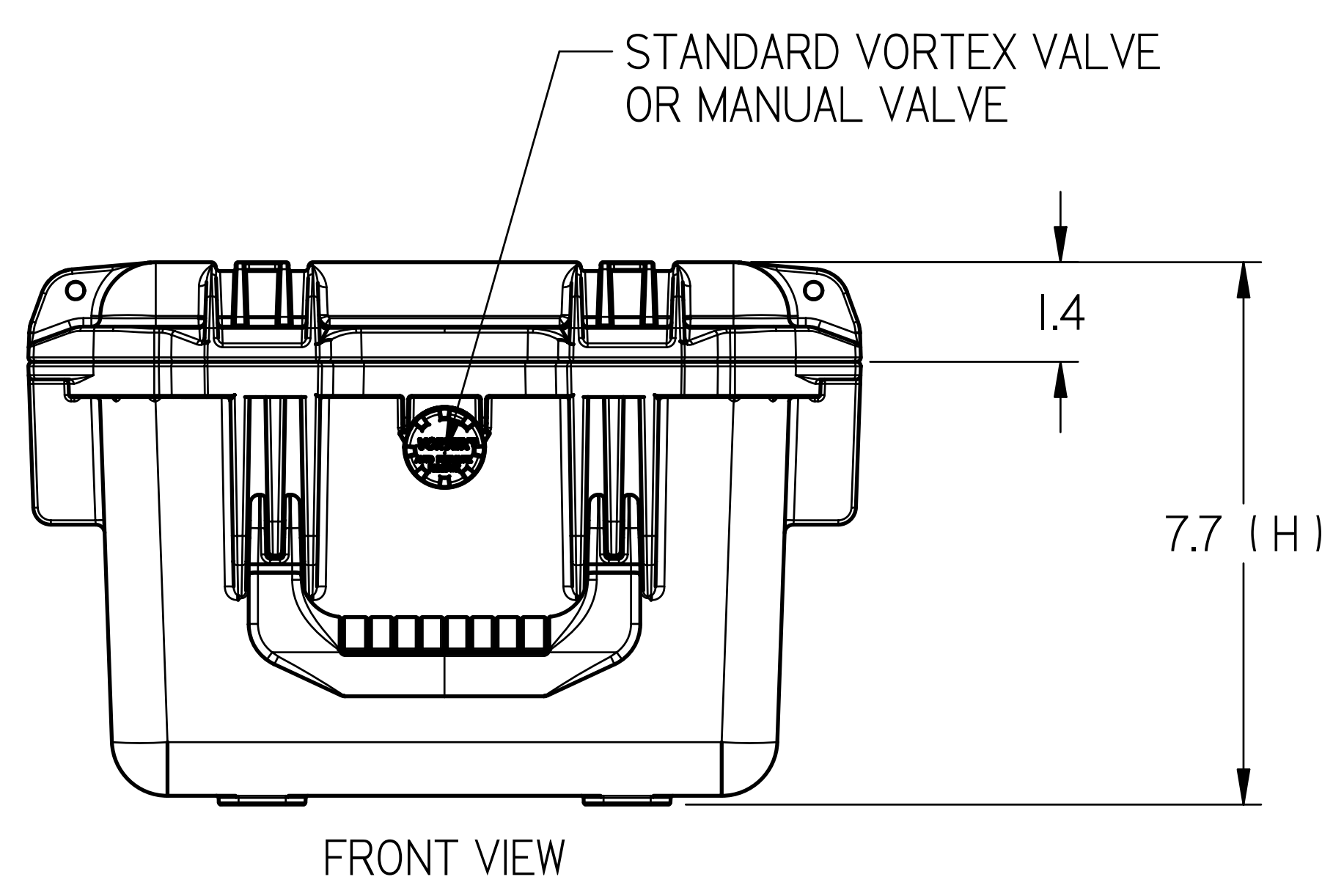

RIGHT SIDE VIEW

Model No.:	iM2075
Case Weight (lbs. Empty)	3.3 lbs.
Interior Length	09.5 in [241 mm]
Interior Width	07.5 in [191 mm]
Interior Height (overall)	7.25 in [184 mm]
Interior Lid Height	1.25 in [031 mm]
Exterior Length (L)	11.8 in [299 mm]
Exterior Width (W)	09.8 in [248 mm]
Exterior Height (H)	07.7 in [195 mm]
Master Pk. Qty.	-
Master Pk. Wt.	- lbs

**RECOMMENDED MAX PAYLOAD 15 LBS**

COMPUTER CONTROLLED DOCUMENT  
MANUAL CHANGES NOT ALLOWED

**NOTES;**  
SEE STORM CASE LITERATURE FOR STANDARD CASE COLORS, CUSHION INTERIORS, AND P/N FOR ORDERING.  
**FOR REFERENCE ONLY**

<small>This drawing and all copies and the design and data shown are the property of HARDIGG INDUSTRIES, INC. So. Deerfield, MA U.S.A. and include proprietary information. The borrower by receipt or retention of the drawing agrees that, except as expressly authorized in writing by HARDIGG INDUSTRIES, INC. it will (1) not use the drawing or any copy of the design or data shown (2) not reproduce, copy, excerpt, exhibit or distribute the drawing or any copy for use by others and (3) upon demand return the drawing, all copies and all material copies therefrom.</small>				<b>147 North Main Street P.O. Box 201 South Deerfield, MA 01373-0201 USA T: 413-665-2163 or 800-542-7344 F: 413-665-8061 <a href="http://www.stormcase.com">http://www.stormcase.com</a></b>	
				<b>TITLE: Hardigg Storm Case</b>	
SIZE	CAGE CODE	Model No.	REV.		
D	11214	iM2075	01		
Scale 1/2			Sht No. 1 of 1		