

TOP VIEW

PADLOCKABLE HASP LOCATIONS (2)

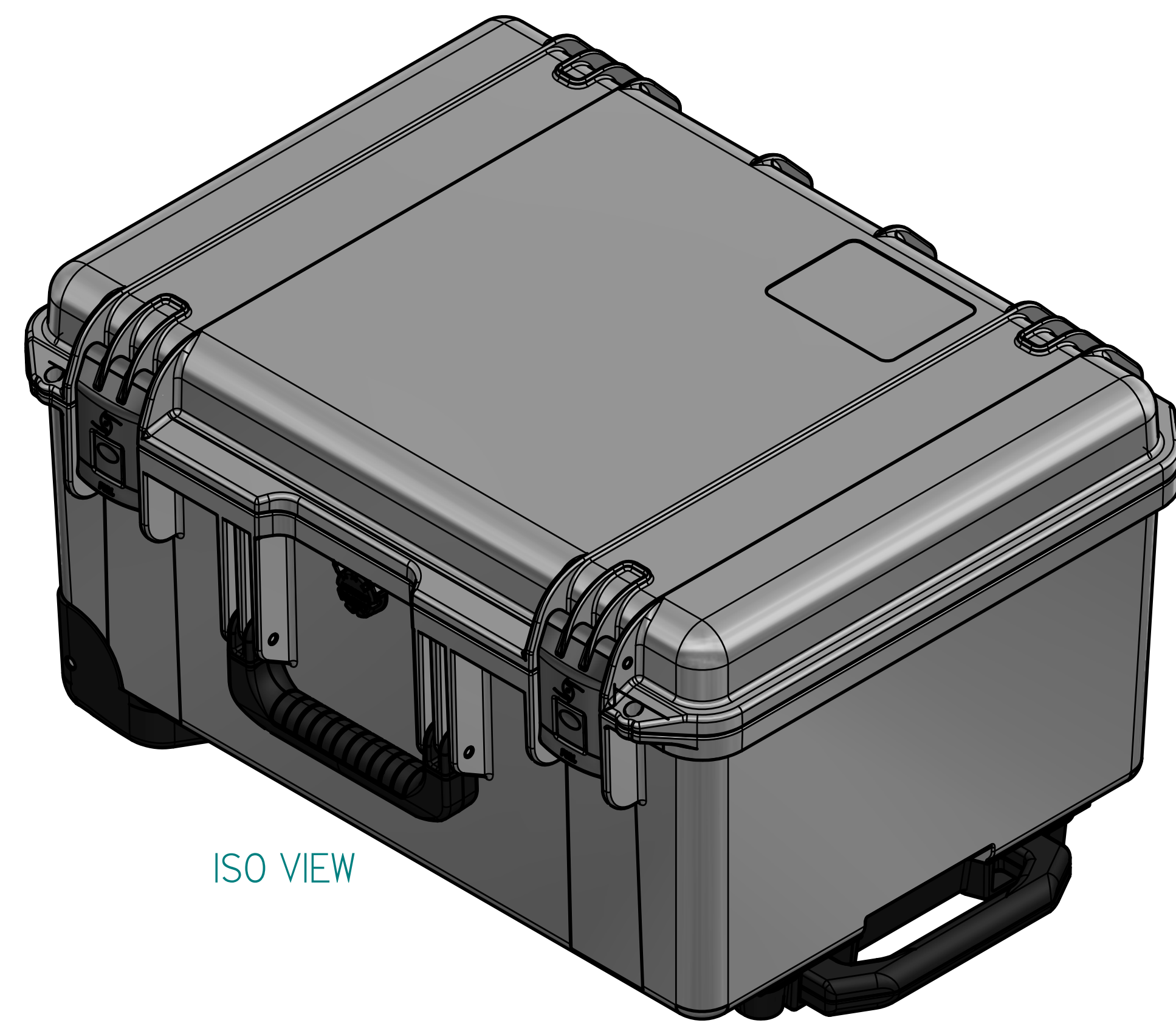

ISO VIEW

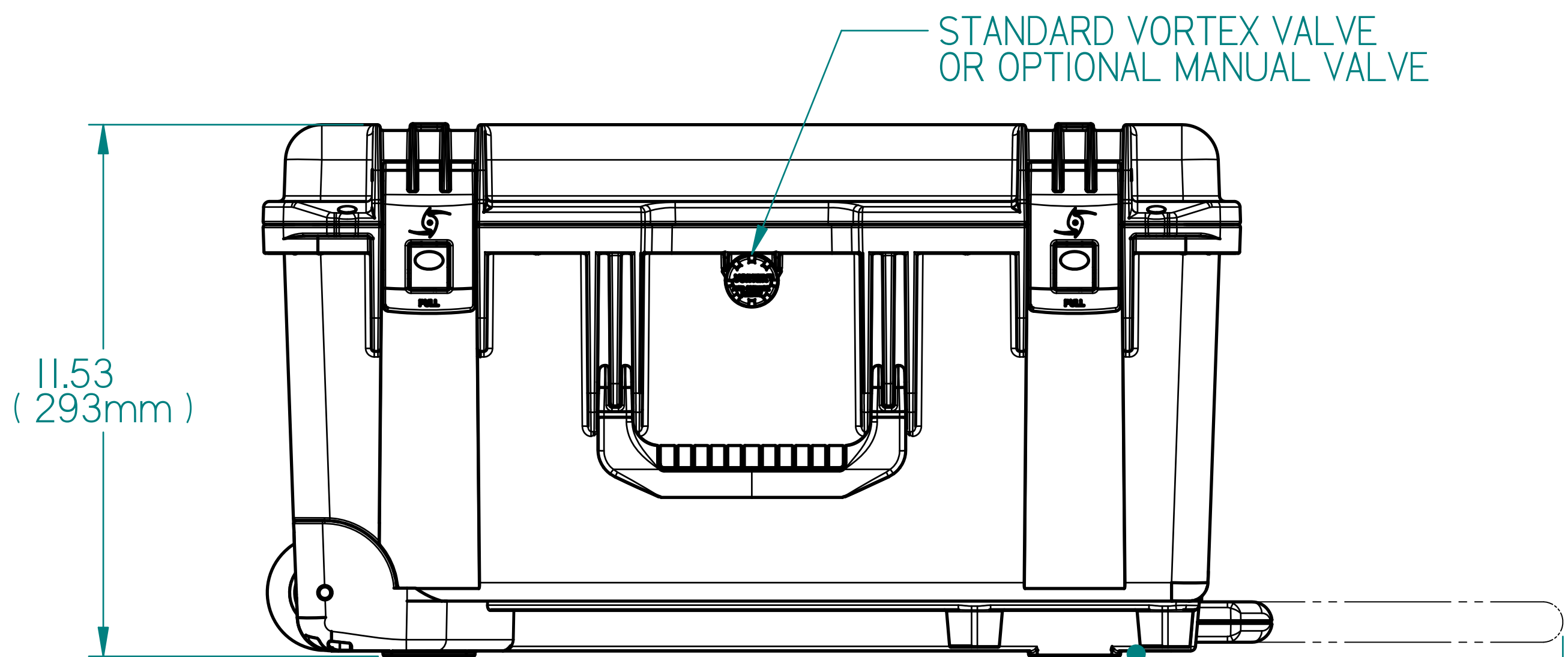

FRONT VIEW

TELESCOPING HANDLE WITH WHEELS

16.50 (419mm) (EXTENDED LENGTH)

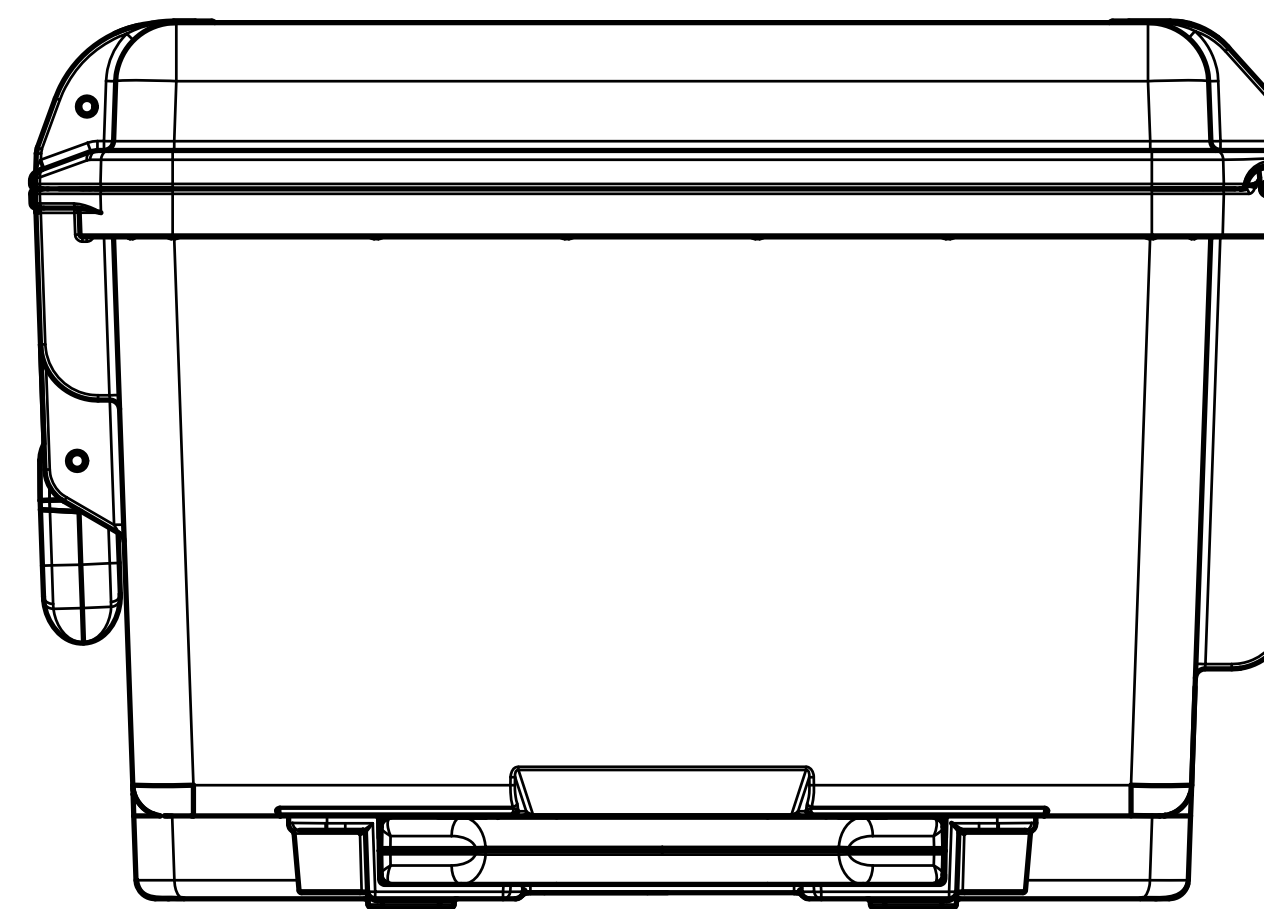

SIDE VIEW

Model No.:	iM2620
Case Weight (lbs. Empty)	12.5 lbs. (5.6 kg)
Interior Length	19.8 in [502 mm]
Interior Width	13.8 in [350 mm]
Interior Height (overall)	10.0 in [254 mm]
Interior Lid Height	02.0 in [050 mm]
Exterior Length (L)	21.2 in [538 mm]
Exterior Width (W)	16.2 in [411 mm]
Exterior Height (H)	11.4 in [289 mm]
Master Pk. Qty.	2
Master Pk. Wt.(CASE EMPTY)	30.5 lbs(13.8 kg)

RECOMMENDED MAX PAYLOAD: 50 lbs (22.6kg)

COMPUTER CONTROLLED DOCUMENT
MANUAL CHANGES NOT ALLOWED

NOTES;

SEE STORM CASE LITERATURE FOR STANDARD CASE COLORS, CUSHION INTERIORS, AND P/N FOR ORDERING.

FOR REFERENCE ONLY

This drawing and all copies and the design and data shown are the property of HARDIGG INDUSTRIES, INC. So. Deerfield, MA U.S.A. and include proprietary information. The borrower by receipt or retention of the drawing agrees that, except as expressly authorized in writing by HARDIGG INDUSTRIES, INC. it will (1) not use the drawing or any copy of the design or data shown (2) not reproduce, copy, excerpt, exhibit or distribute the drawing or any copy for use by others and (3) upon demand return the drawing, all copies and all material copies therefrom.

**147 North Main Street
P.O. Box 201
South Deerfield, MA
01373-0201 USA
T: 413-665-2163 or
800-542-7344
F: 413-665-8061
<http://www.stormcase.com>**

TITLE: Hardigg Cartable Storm Case			
SIZE	CAGE CODE	Model No.	REV.
D	11214	iM2620	-
Scale 1/2	Sht No.		1 of 1